

LOCKZONE Base

Vortex air diffuser for raised floors



QUICK FACTS

- Robust sheet steel design
- Manages airflows substantially below room temperature
- High induction function
- Cleanable
- ALS commissioning box with damper function or dirt trap LOCKZONE T as accessories
- Available in alternative colours

AIR FLOW - SOUND LEVEL						
LOCKZONE B with LOCKZONE T	25 dB(A)		30 dB(A)		35 dB(A)	
	l/s	m ³ /h	l/s	m ³ /h	l/s	m ³ /h
Size						
100	12	43	14	50	17	61
125	17	61	19	68	23	83
160	23	83	28	101	32	115
200	44	158	50	180	58	209

Technical description

Design

Circular supply air diffuser for installation in a floor where the diffuser face has guide-vane perforations arranged in a circular pattern for vortex air distribution.

Materials and finish

The duct diffuser is made of galvanized sheet steel. The air diffuser is supplied with a connection frame fitted with a spigot connection. LOCKZONE B is as standard powder painted in a grey colour, RAL 7037, with an extra durable surface finish.

Customizing

To special order, the air diffuser can be supplied in other sizes, colours, etc. For further particulars, get in touch with your nearest Swegon representative.

Accessories

Dirt trap:

LOCKZONE Trap: Made of galvanised sheet steel.

Commissioning box:

ALS: Made of galvanised sheet steel. The box contains a removable commissioning damper, fixed measurement tapping and sound absorbent insulation covered by a reinforced surface layer, rated to Fire resistance class B-s1,d0 conforming to EN ISO 11925-2. Tightness class C on the housing according to SS-EN 12237 and VVS/AMA 12.

Project planning:

If the space below the raised floor is used as a so-called pressure chamber, it is advisable to use the LOCKZONE T dirt trap accessory. The total airflow in the pressure chamber should then be checked by means of a flow measurement and control damper, to be placed in the connecting duct system. The pressure rise in the air diffuser ensures a uniform airflow across all the air diffusers installed in the system.

If the raised floor is not to be used as a so-called pressure chamber, the ALS commissioning box can be used for obtaining the damper and flow measurement function. Then connect the air diffuser together with the ALS commissioning box to the duct system.

Installation

Cut an opening in the floor according to the floor opening dimension specified. See Dimensions and weight.

Fix the mounting frame to the flooring with screws in the edge of the frame. Place the air diffuser onto the mounting frame and secure it with the centre screw. If an ALS commissioning box is used, it must be secured to the building structure. See Figure 1.

The distance between the commissioning box and the air diffuser can be increased by as much as 500 mm without having to lengthen the measuring tubes and damper adjustment cords.



Commissioning

LOCKZONE B is not equipped with a damper or measuring gauge. To measure the airflow it is advisable to install a flow measurement and control damper in the duct system upstream of the so-called pressure chamber. The total airflow in the pressure chamber can then be checked using this flow measurement and control damper.

Both the flow measurement and damper functions will be obtained if the ALS commissioning box is used. Commissioning should be carried out with the diffuser face mounted. Pull the measuring tubes and damper adjustment cords out through the diffuser face after you have opened it. Then refit the diffuser face. Connect a manometer to the measuring tubes. The desired commissioning pressure can be computed by applying the rated coefficient of performance of the air diffuser. Set the damper to the correct blade position, tie a commissioning knot in the damper cords to indicate the damper position. See Figure 2.

Measurement accuracy and requirement on straight duct before the commissioning box, see Figure 1. The requirements of straight duct depends on the type of disturbance before the commissioning box. Figure 1 shows a bend, a dimensional change and a T-piece. Other types of disturbances requires at least 2xD straight (D = connection dimension) for measurement accuracy of $\pm 10\%$ of the flow.

The rated coefficient of performance (K-factor) is specified on the identification label of the product and in the relevant commissioning instructions at www.swegon.com.

Maintenance

The air diffuser can be cleaned, if necessary, using lukewarm water with dishwashing detergent added or by vacuum cleaning using a brush nozzle. The duct system can be reached for cleaning after opening the diffuser face. If a type ALS commissioning box is used, swing the distribution plate to the side so that you then can grip the handle of the tubular damper casing and rotate it out of its holder. See Figures 2 and 3.

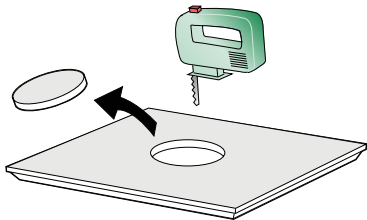

Commissioning box

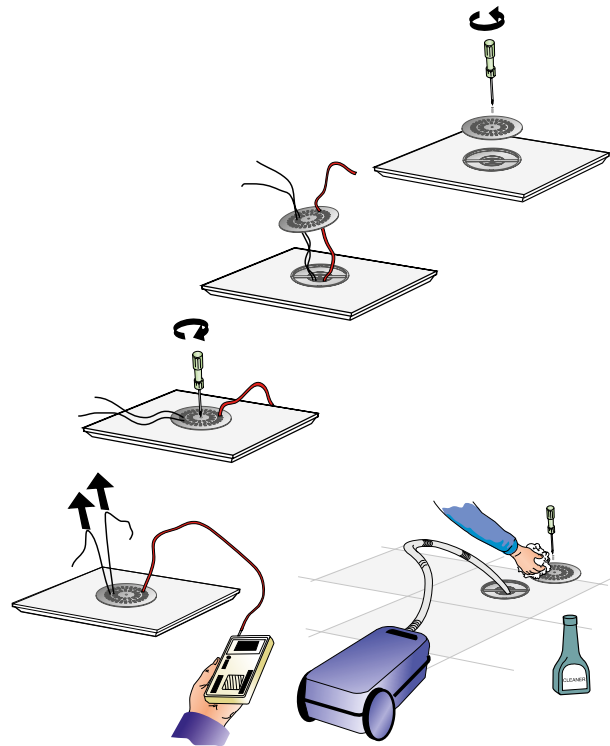
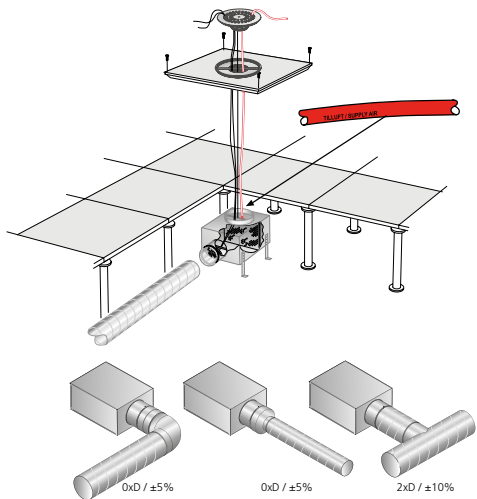

Figure 2. Commissioning. Maintenance.

Dirt trap

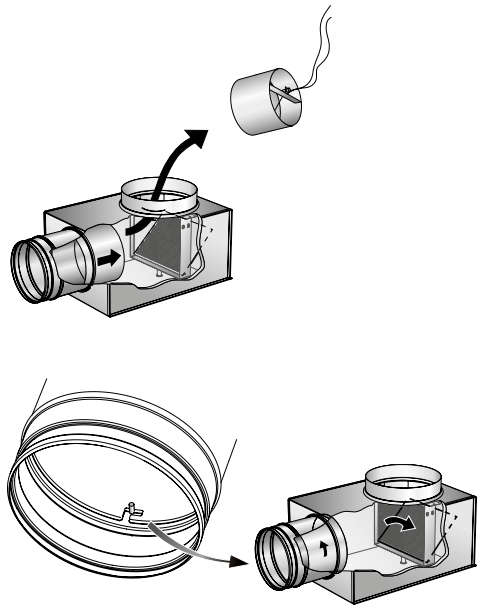
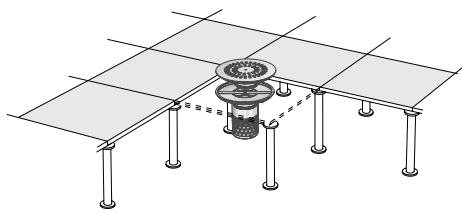

Figure 3. Damper removal.

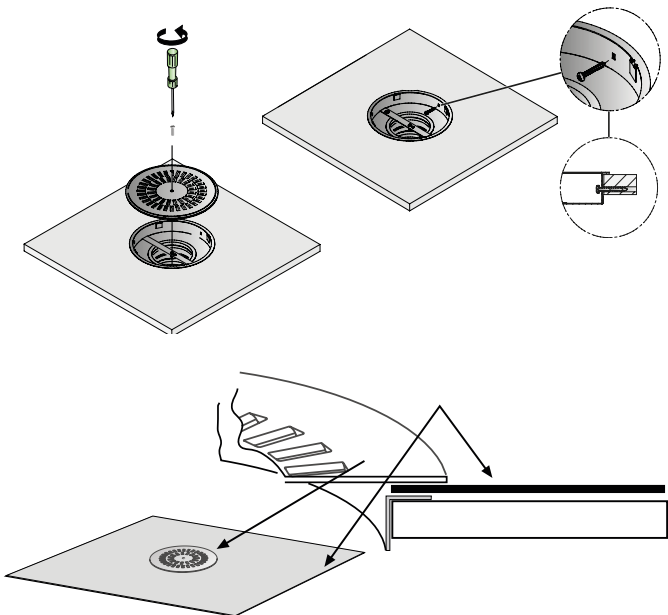

Figure 1. Installation

Sizing

- Sound level dB(A) applies to rooms with 10 m² equivalent sound absorption area.
- Throw $l_{0,2}$ is isothermally measured.
- For calculating the width of the air stream, air velocities in the occupied zone or sound levels in rooms with other dimensions, please refer to our web calculation softwares available for download at www.swegon.com.

Sound data

LOCKZONE B – Supply air

Sound power level L_w (dB)

Table K_{OK}

Size LOCKZONE B +LOCKZONE T	Mid-frequency (Octave band) Hz							
	63	125	250	500	1000	2000	4000	8000
100	-1	0	1	0	2	-6	-20	-28
125	0	1	1	1	-1	-3	-12	-24
160	-2	0	1	2	0	-5	-14	-22
200	-1	-1	1	2	0	-5	-19	-27
Tol. ±	2	2	2	2	2	2	2	2

Sound Attenuation ΔL (dB)

Table ΔL

Storlek LOCKZONE B +LOCKZONE T	Mid-frequency (Octave band) Hz							
	63	125	250	500	1000	2000	4000	8000
100	22	16	11	4	2	3	8	12
125	20	15	10	4	2	2	8	11
160	19	14	9	4	1	2	7	9
200	18	13	8	4	1	1	6	7
Tol. ±	2	2	2	2	2	2	2	2

LOCKZONE B + ALS – Supply air

Sound power level L_w (dB)

Table K_{OK}

Size LOCKZONE B +ALS	Mid-frequency (Octave band) Hz							
	63	125	250	500	1000	2000	4000	8000
100	-7	5	3	-1	1	-5	-17	-25
125	-3	5	6	-1	-1	-3	-12	-20
160	-2	2	6	1	-2	-5	-13	-21
200	-1	4	5	1	-1	-5	-14	-22
Tol. ±	2	2	2	2	2	2	2	2

Sound attenuation ΔL (dB)

Table ΔL

Size LOCKZONE B +ALS	Mid-frequency (Octave band) Hz							
	63	125	250	500	1000	2000	4000	8000
100	23	16	14	17	17	13	15	18
125	22	15	13	16	17	13	14	17
160	21	14	13	16	16	12	14	17
200	19	13	11	15	14	12	12	16
Tol. ±	2	2	2	2	2	2	2	2

Sizing diagram

LOCKZONE B + LOCKZONE T – Supply air

Air flow – Pressure drop – Sound level – Throw

- The diagrams illustrate data for the LOCKZONE B recessed in a floor.
- The diagrams should not be used for commissioning.
- The dB(C) value is normally 6-9 dB higher than the dB(A) value.

LOCKZONE B + LOCKZONE T

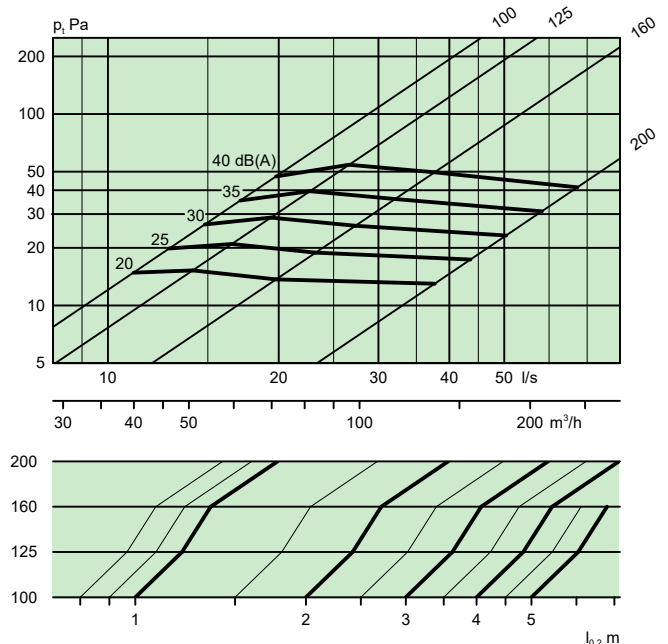

LOCKZONE B + ALS – Supply air

Air flow – Pressure drop – Sound level – Throw

- The diagrams illustrate data for the LOCKZONE B recessed in a floor.
- The diagrams should not be used for commissioning.
- ∇ = Min. airflow required for obtaining sufficient commissioning pressure.
- The dB(C) value is normally 6-9 dB higher than the dB(A) value.

LOCKZONE B 100 + ALS 80–100

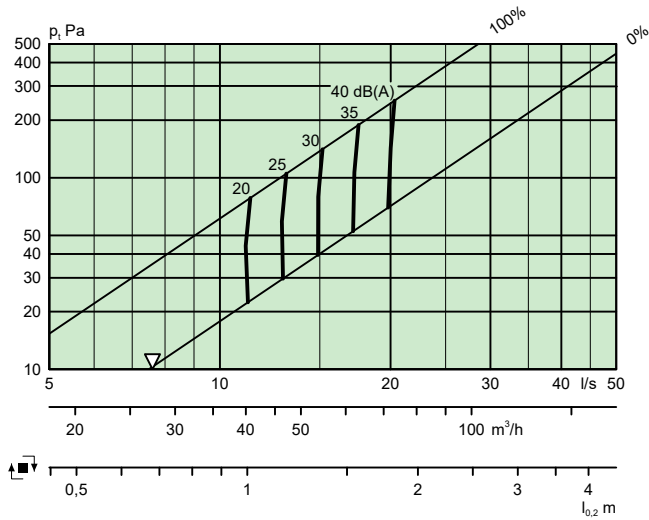

LOCKZONE B 125 + ALS 100–125

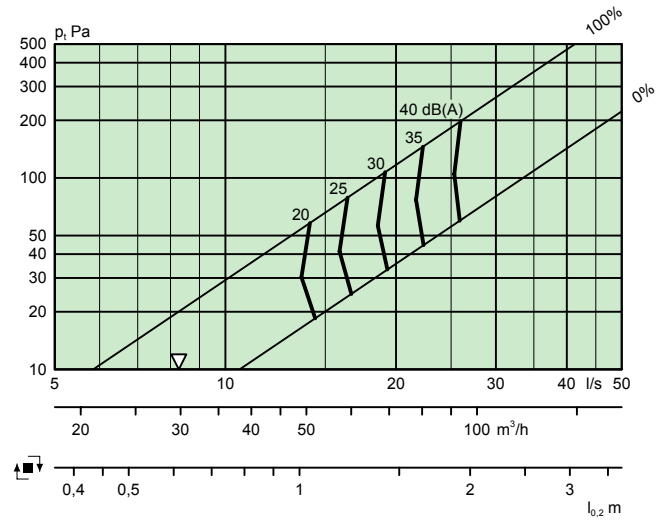

LOCKZONE B 160 + ALS 125–160

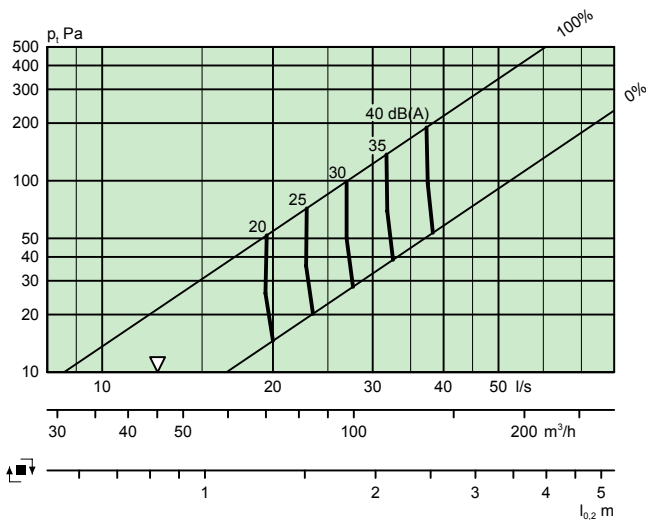

LOCKZONE B 200 + ALS 160–200

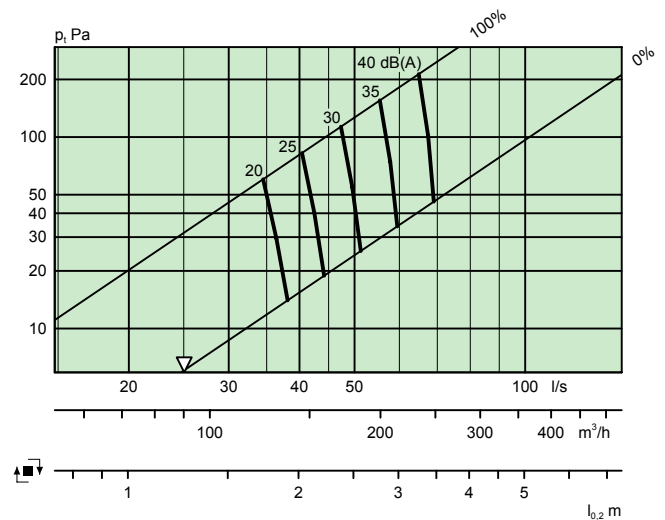

Figure 4. Isovel.

$h_{0,2}$ max 0,1 m isothermally measured.

q size 100 = 15 l/s

q size 125 = 25 l/s

q size 160 = 25 l/s

For size 200:

$h_{0,2}$ max 0,1 m at isothermical measuring if q size 200 \leq 30 l/s

$h_{0,2}$ max 0,2 m at isothermical measuring if q size 200 \leq 50 l/s

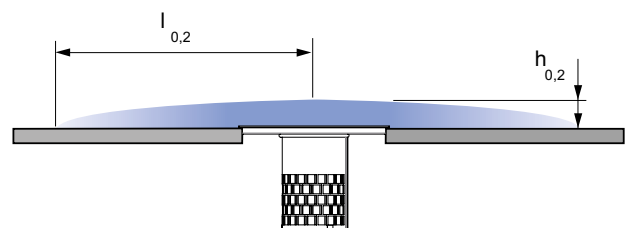

Dimensions and weights

LOCKZONE B + LOCKZONE T

Size	ØA	ØB	ØD	ØC	ØE	Weight, kg
100	99	100	192	196	220	1,4
125	124	125	228	232	265	1,6
160	159	160	228	232	265	1,7
200	199	200	304	310	345	2,3

ØC = Size of floor opening.

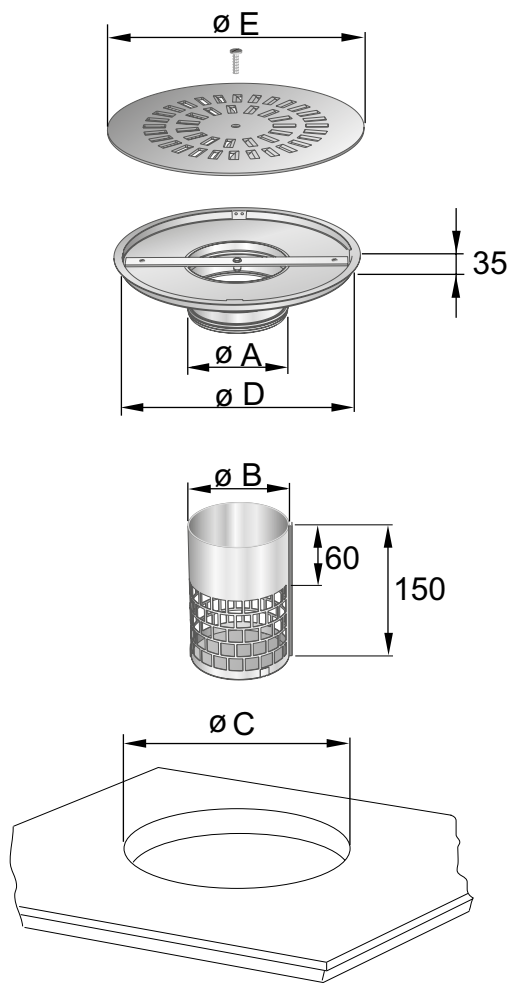

Figure 5. LOCKZONE B + LOCKZONE T.

ALS

Size	B	C	ØD	Ød	F	G	H	K	Weight, kg
80-100	227	192	79	100	162	90	200	48	1.5
100-125	282	217	99	125	182	100	275	83	2.0
125-160	342	252	124	160	206	113	318	83	2.5
160-200	404	288	159	199	240	132	375	100	3,3

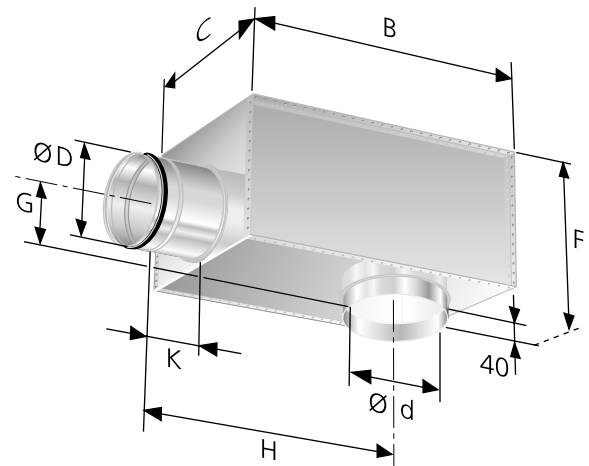

Figure 6. ALS.

Ordering key

Product

Circular low momentum air diffuser for raised floor with mounting frame LOCKZONE B b -aaa

Version:

Size: 100, 125, 160, 200

Accessories

Dirt trap LOCKZONE T a -aaa

Version:

Size: 100, 125, 160, 200

Commissioning box ALS d -aaa-bbb

Version:

For LOCKZONE B 100: ALS 80-100

For LOCKZONE B 125: ALS 100-125

For LOCKZONE B 160: ALS 125-160

For LOCKZONE B 200: ALS 160-200

Specification text

Swegon's circular low momentum air diffuser for installation in a raised floor, type LOCKZONE B, with the following functions:

- Made of 2 mm thick galvanised sheet steel.
- Non-fouling design
- Diagonal slots for a flat air distribution pattern
- Cleanable
- Painted in a grey colour, RAL 7037

Accessories:

Dirt trap: LOCKZONE Ta – aaa xx items

Size: LOCKZONE Bb – aaa xx items